



## Remote Pull-to-Lock Chamber

**omni brake**<sup>®</sup>

# OMNIBRAKE

TSE Brakes offers a unique “pull-to-lock” chamber as part of its OmniBrake family. This chamber was originally designed as a tailgate lock for dump trucks/trailers that allowed drivers to release the tailgate when air pressure is applied. In addition to use as a tailgate lock, the remote chamber has found many new markets, including use as a drawbar lift and clamp apparatus.

### **Better Design**

The OmniBrake remote chamber features TSE's patented design with a completely sealed, all steel housing and center section. The main spring is made from chrome silicon pre-tempered wire and specially coated to provide you with premium life and durability characteristics.

### **Corrosion Protection**

OmniBrake remote chambers undergo TSE's in-house full immersion e-coating of housing and internal components, guaranteeing 100% coating and consistent thickness for excellent corrosion protection.

### **Stroke**

The remote chambers are available in a 2.5" and 3" stroke, with custom specifications available upon request.

### **Warranty**

OmniBrake remote chambers feature a 3-year warranty standard and 2 years for severe service applications.

# REMOTE PULL-TO-LOCK CHAMBER

OMNIBRAKE

## 30RPC2 & 30RPC3

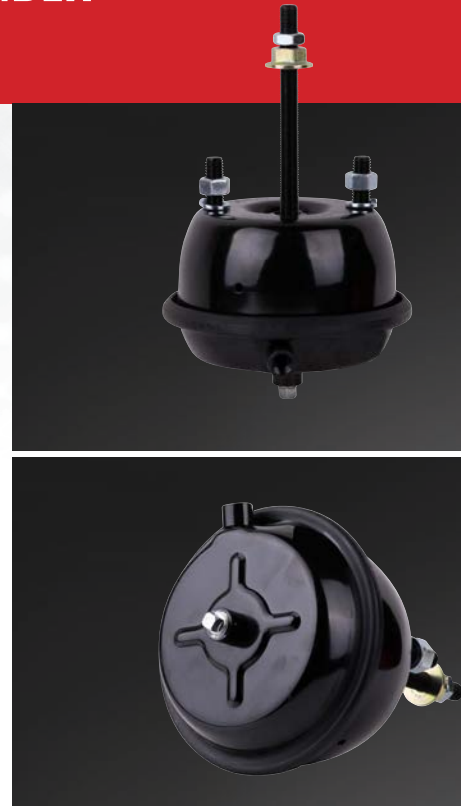
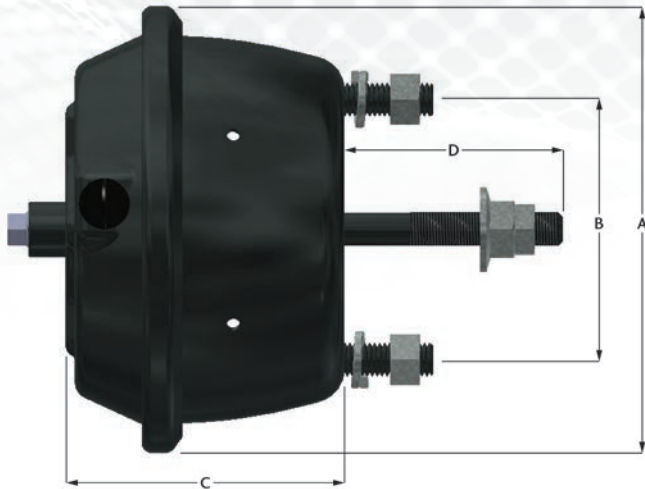

PART NUMBER	Stroke (in.)	Service Volume (in.3)	Weight (lbs)	A (in.)	B (in.)	C (in.)	D (in.)	Inlet Ports	Mounting Studs
30RPC2	2.50	92	12.7	8.1	4.75	5.1	Customer Specified	3/8-18 NPTF	5/8-11 UNC
30RPC3	3.00	110	12.9	8.1	4.75	5.1	Customer Specified	3/8-18 NPTF	5/8-11 UNC

**30RPC2 (30SCL2R)**  
Chamber Performance

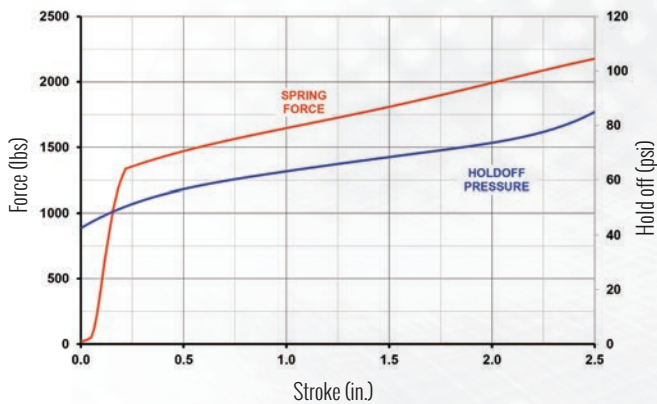

**30RPC3 (30SCL3R)**  
Chamber Performance

